

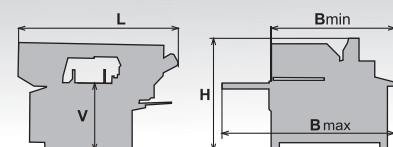

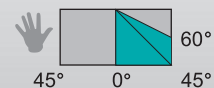







# PEGAS

## 220x250 A-NC-R



| mm   | 0°      | 45°     | 60°    |  $\frac{b}{a \times b}$ |
|--|---------|---------|--------|--|
|                           | 220     | 160     | 90     | X  |
|                           | 120*    | 85*     | 55*    | X  |
|  $\frac{a}{b} a \times b$ | 230x190 | 160x90  | 90x90  | 230x120  |
|  $\frac{a}{b} a \times b$ | 230x190 | 140x190 | 80x160 | 230x120  |

|  |  kW |  m/min |  mm |     |  kg |
|---|--|---|--|-----|--|
| 3x400V<br>50 Hz   | 0,75/1,1   | 30/65   | 2450x27x0,9  |     | 550  |
| L   | Bmax   | Hmin  | Hmax   | V   |  |
| 1970  | 1590   | 1570  | 1750   | 925 |  |

\*doporučené hodnoty/ recommended values



# PEGAS

## 220x250 A-NC-R



**OPTION**

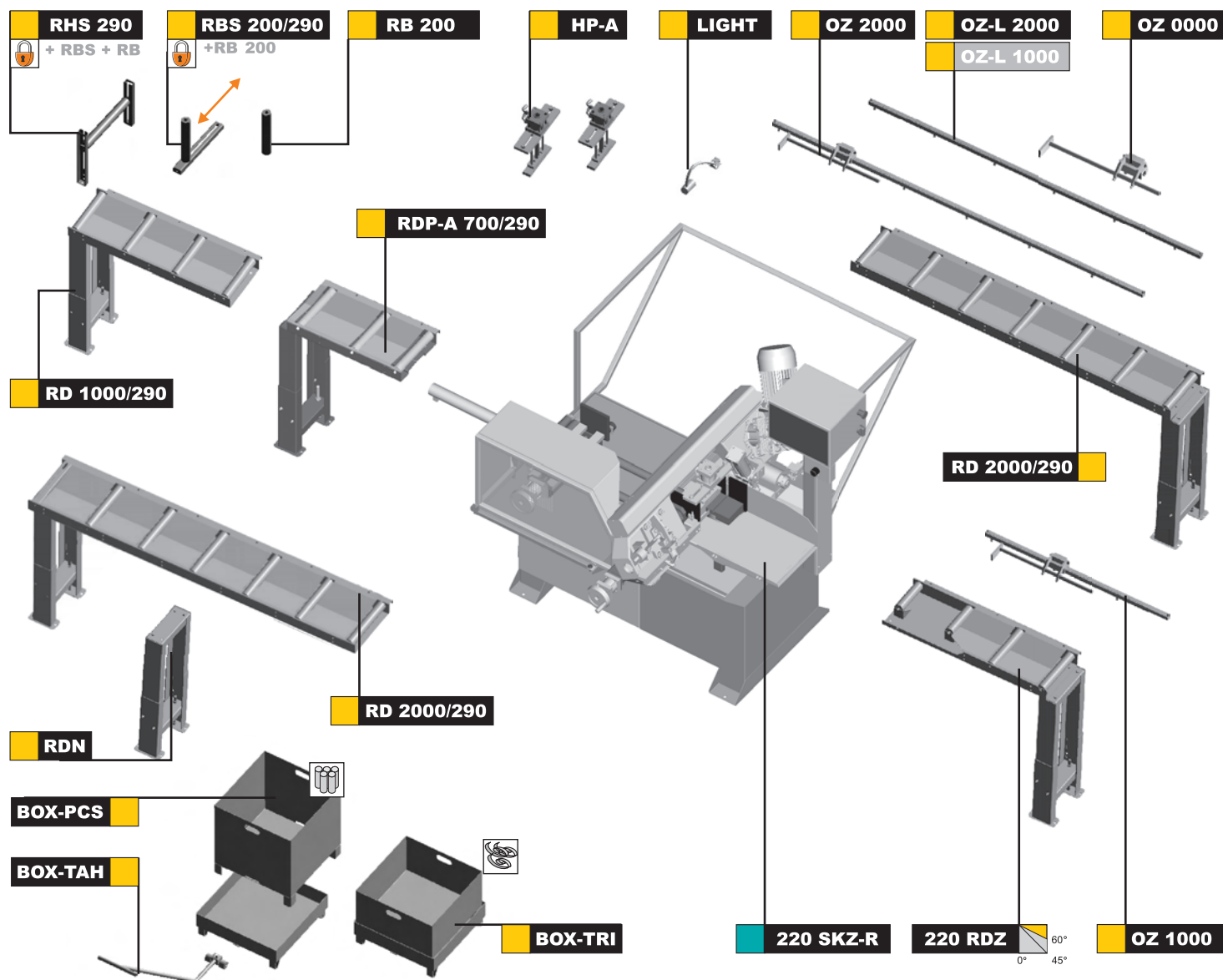
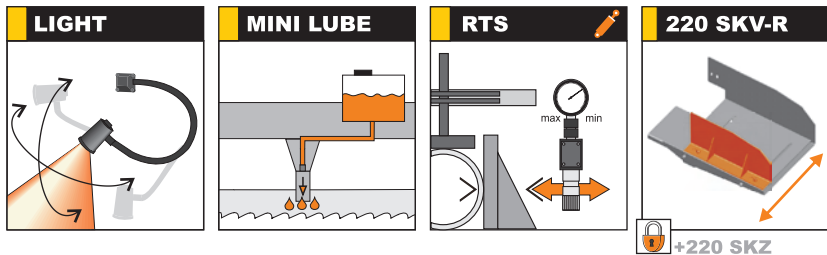

■ STANDARD   ■ OPTION



PEGAS-GONDA s.r.o., Čs. armády 322, 684 01 Slavkov u Brna  
Tel: 00420-544 221 125, 00420-544 221 126, fax: 00420 544 227 389  
E-mail: pegas@gonda.cz, [www.pegas-gonda.cz](http://www.pegas-gonda.cz), Czech Republic

- výrobce si vyhrazuje právo provádět změny technických údajů, technické údaje odpovídají 1.5.2010  
- producer has the right to make changes of technical data, technical data are valid on 1.5.2010/  
- pila na fotografii není vždy v základním provedení / the machine in the picture is not always in the basic version  
- uvedené rozměry odpovídají stroji v základním provedení / mentioned diameters are for machine in basic version/