

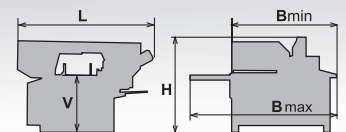

290x290 X-CNC-1500-F

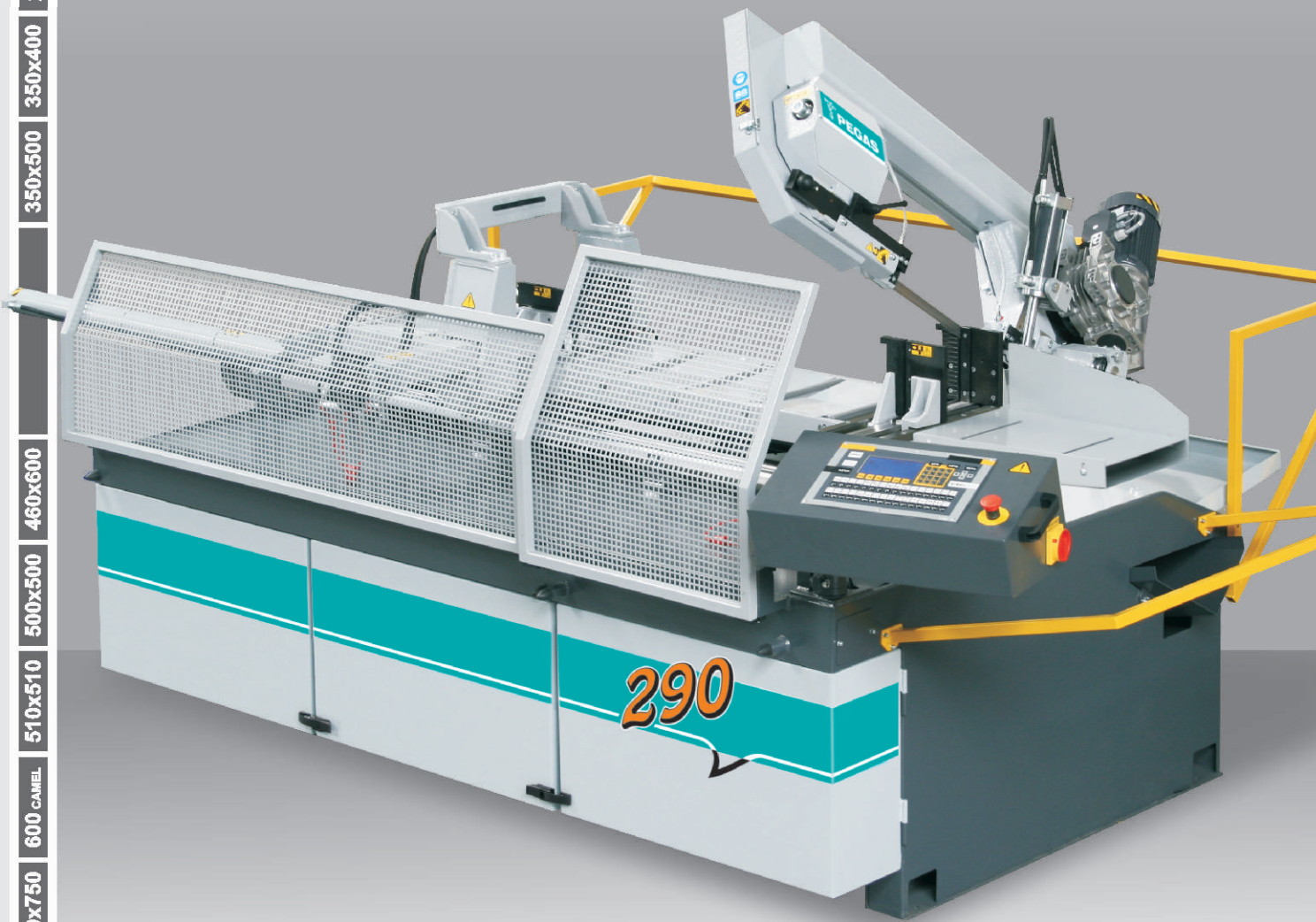
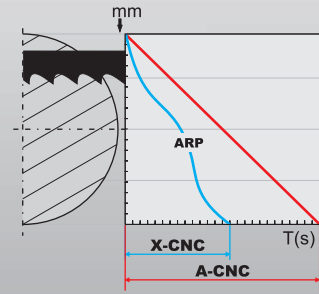
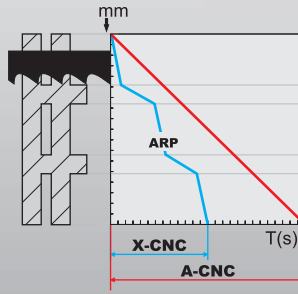
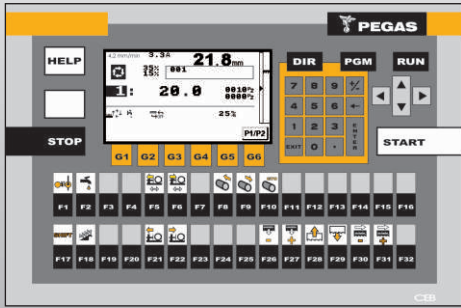

mm	0°	a b	a b
	290	X	X
	180*	X	X
a x b	300x260	300x160	230x140
a x b	300x260	300x160	230x140

3x400V 50 Hz	2,2	20-100	3100x27x0,9		1200
L	Bmin	Bmax	Hmin	Hmax	V
1900	3050	4250	1600	2200	940

*doporučené hodnoty /recommended values



PEGAS

A	1515
B	80
C	60

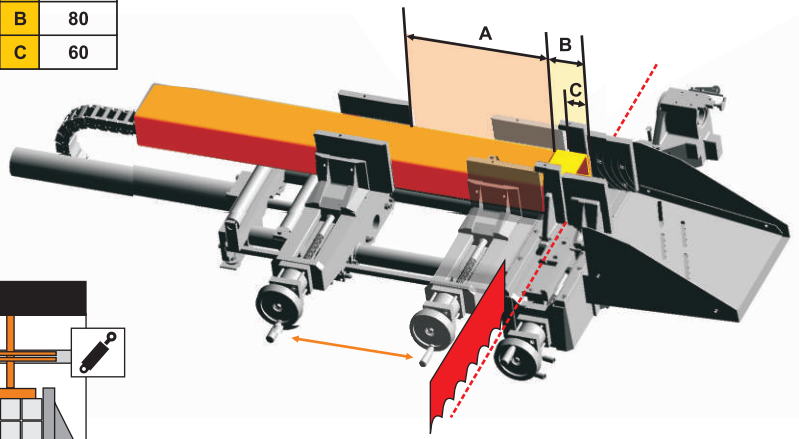

290x290 X-CNC-1500-F

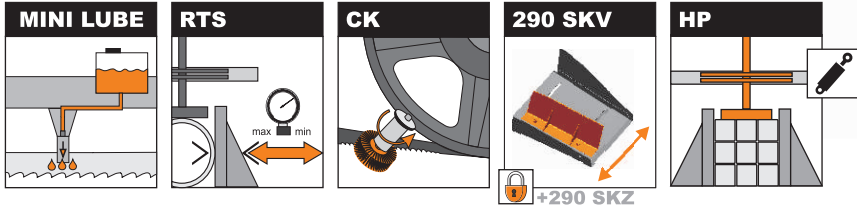

OPTION

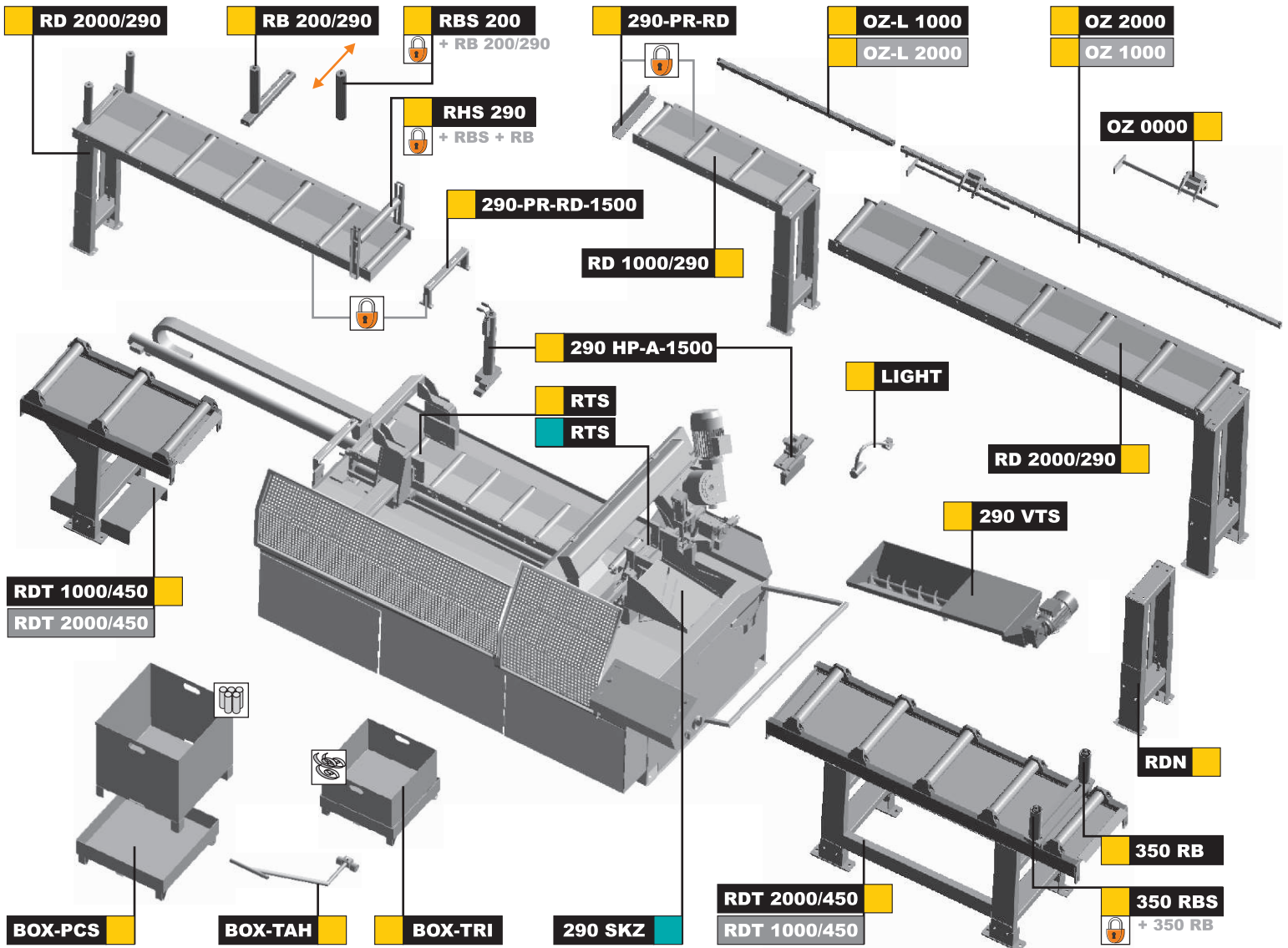

■ STANDARD ■ OPTION



PEGAS-GONDA s.r.o., Čs. armády 322, 684 01 Slavkov u Brna
 Tel: 00420-544 221 125, 00420-544 221 126, fax: 00420 544 227 389
 E-mail: pegas@gonda.cz, www.pegas-gonda.cz, Czech Republic

- výrobce si vyhrazuje právo provádět změny technických údajů, technické údaje odpovídají 1.1.2011
 /producer has the right to make changes of technical data, technical data are valid on 1.1.2011/
 - píla na fotografii není vždy v základním provedení /the machine in the picture is not always in the basic version
 - uvedené rozměry odpovídají stroji v základním provedení /mentioned diameters are for machine in basic version/