

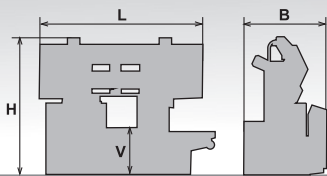

**510x510 HERKULES X**

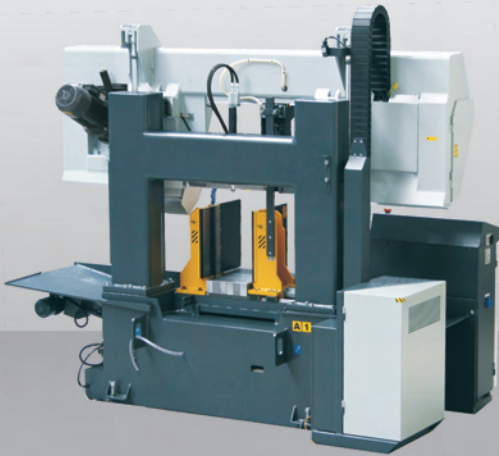

510	510*	$\frac{b}{a \times b}$	$\frac{b}{a \times b}$
		510x560	500x450

\*doporučené hodnoty / recommended values

●	3x400V 50 Hz	7,5	15-80	6060x54x1,6	3750

L	B	Hmin	Hmax	V	
3100	1500	2100	2600	800	



# PEGAS

## 510x510 HERKULES X

**NEW**

500 RDP 1000/620

500 RBR

500 HP

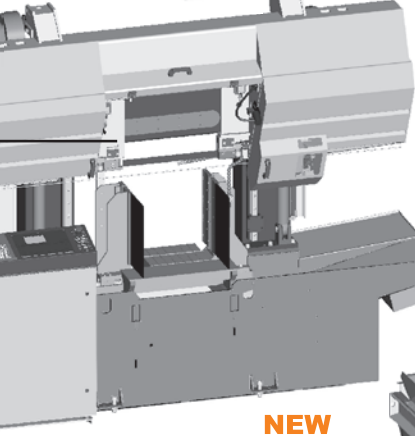

500 HPV

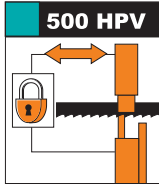

500 RDH



**NEW**

500 VZM

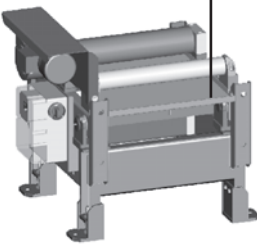

500 RBR



500 RDT 2000/620

**NEW**

500 RDZ 1000/620

500 RDM 2000/620

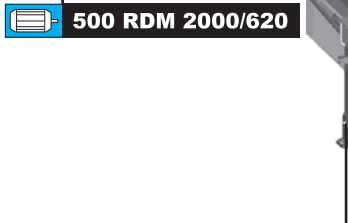

500 RDML 2000/620

500 RDML 1000/620

+RDM

500 OZS 2000

500 OZSD 2000

+RDM

**NEW: 500 VZM**

1)

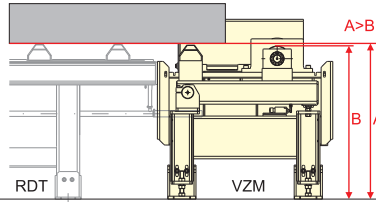

2)

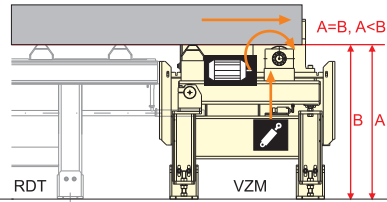

### OPTION

500 VTS

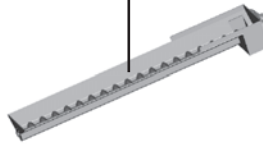

500 RBRS

+RBR

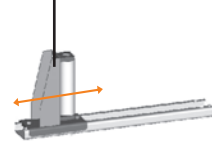

500 RBR



**NEW**

500 RDZ-SKZ 2000

+BOX-PCS

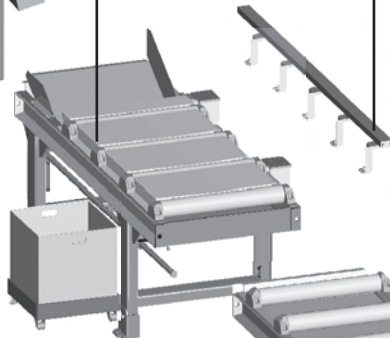

500 OZP-L 2000

500 OZD-L 2000

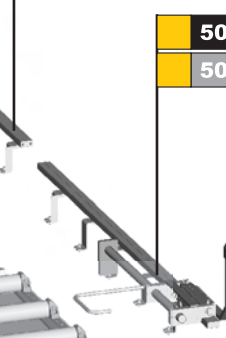

500 OZP 2000

500 OZP 1000

500 OZP-D 2000

500 OZP-D 1000



500 V

+RDT

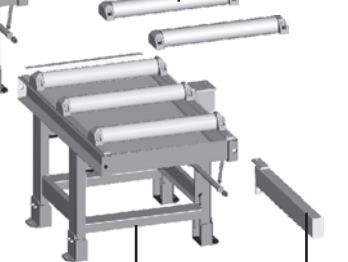

**NEW**

500 RDZ 1000/620



500 RDT 1000/620



500 OZK



BOX-TAH

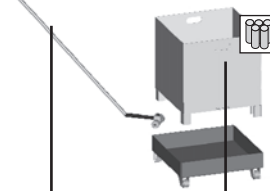

BOX-PCS

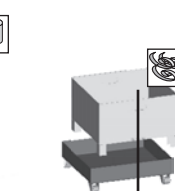

BOX-TRI

STANDARD OPTION



PEGAS-GONDA s.r.o, Čs. armády 322, 684 01 Slavkov u Brna  
Tel: 00420-544 221 125, 00420-544 221 126, fax: 00420 544 227 389  
E-mail: pegas@gonda.cz, www.pegas-gonda.cz, Czech Republic

- výrobce si vyhrazuje právo provádět změny technických údajů, technické údaje odpovídají 1.1.2011  
- producer has the right to make changes of technical data, technical data are valid on 1.1.2011/  
- píla na fotografiích není vždy v základním provedení / the machine in the picture is not always in the basic version  
- uvedené rozměry odpovídají stroji v základním provedení / mentioned diameters are for machine in basic version/